



Irrigation

Quick Pressure Relief Valve, 2-way

The Eliptix Level control Valve - Vertical Float model R-30 Y is used to maintain a preset minimum and maximum water level in a reservoir or water tank. The valve is activated by line pressure according to a modulating bi-level float. The valve will open when the water level of the reservoir reaches the lower preset level of the vertical float. As the water level reaches the maximum preset level of the vertical float, the valve will gradually close by re-pressurizing the control chamber.

Features and Benefits

- Rugged, high quality construction meets applicable engineering standards
- Long service life and low maintenance
- Unique technology, innovative design and performance
- Free and unobstructed liquid flow with minimal head loss
- Designed to reduce cavitation
- Elliptic diaphragm reacts faster with less movement
- Small control chamber enables quicker response

Main Control System Components

No.	Component
1	Finger Filter
2	Ball Valve
3	Restriction Orifice
4	Vertical Float

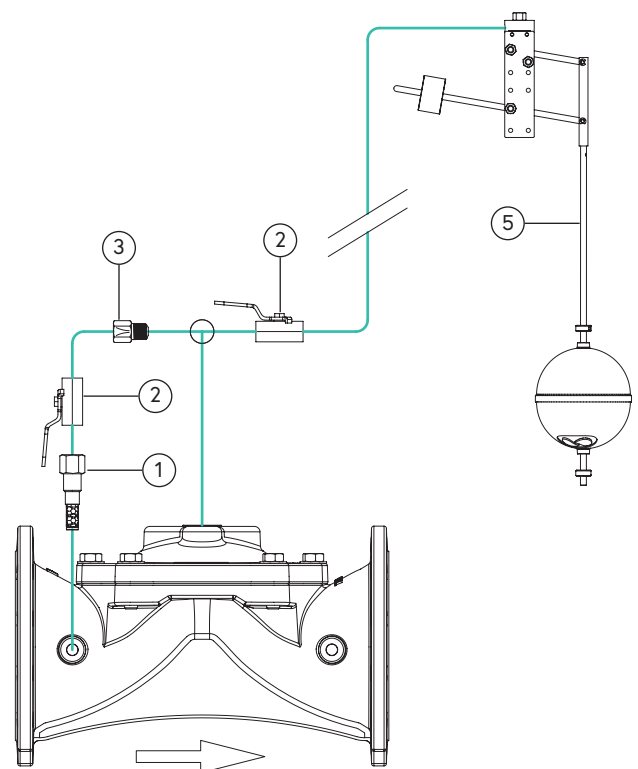

Level control Valve - Vertical Float

Purchase Specifications

The Hydraulic Control Valve shall automatically control upstream pressure in order to protect the system against excessive pressure.

The control valve shall be a hydraulically operated, pilot controlled, weir type, in-line serviceable valve.

The main in-line hydraulic control valve shall have only two moving parts, the resilient diaphragm and the spring.

The diaphragm shall be the only sealing component of the control valve.

Valve Technical Specifications*

Series R-30 PN16

Self-actuated, WEIR type diaphragm actuated, hydraulic control valve

*For dimensions and weights, please refer to the ELIPTIX Basic Valve leaflet

Material	Body & Bonnet	Ductile Iron / Stainless Steel SAE 316
	Diaphragm	Natural Rubber / EPDM
	Spring	Stainless Steel SAE 302
	Spring Seat	Acetal / Stainless Steel SAE 316
	Bolts	Steel, Zinc Cobalt Coated / Stainless Steel SAE 316
	Piping & Tubing	Stainless Steel SAE 316 / Reinforced Nylon
	Coating	Polyester
Pressure Rating	Maximum working pressure - 16 bar Minimum working pressure - 0.4 bar (depending on type of diaphragm)	
Water Temp. Range	5° to 60°C	

Installation and Storage Recommendations

- Always flush the pipeline to remove debris before the installation of the valve.
- Arrow on the valve bonnet must match the actual flow direction.
- Tighten bolts to the recommended torque for the specific size and model of the ELIPTIX valve.
- Do not over-torque.
- Tighten bolts using the crossover method.
- If the ELIPTIX valve is for use in ambient or fluid temperatures below freezing, consult your nearest A.R.I. distributor. If shut down during cold weather, the valve control space and the control system must be drained.

When ordering, please specify

1. ELIPTIX Control Valve Series R-30 model Y
2. ELIPTIX valve size
3. Desired end connection / standard
4. Static inlet pressure (when valve is closed)
5. Dynamic pressures (min – max)
6. Flow rates (min-max)
7. Required discharge pressure