

# ELIPTIX R-20 Series



Irrigation



## Innovative Valves with a Revolutionary Diaphragm Design

The Eliptix R-20 Series hydraulic control valves are built with a strong, corrosion-resistant composite body and feature an innovative elliptical-shaped diaphragm for precise, efficient flow regulation. These valves combine lightweight construction with robust hydraulic control; enabling reliable performance across a wide range of irrigation applications. Ideal for agricultural irrigation systems and water transmission networks, ELIPTIX R-20 series offer durable performance, flexible installation options and reduced maintenance requirements, to meet demands for long-term system efficiency.



## Standout Features

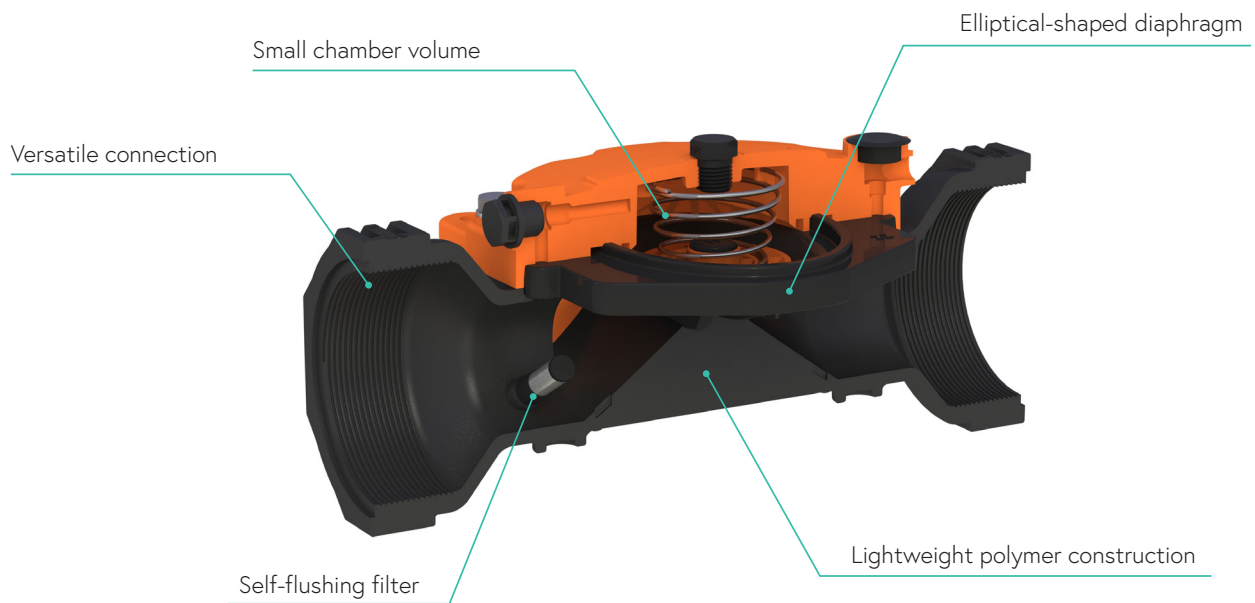

## Features and Benefits

Advanced elliptical-shaped diaphragm	Reduces diaphragm surface area, enabling a smaller control chamber for faster, more precise valve operation. Ensures more uniform irrigation system performance and better infrastructure protection
Wide operating pressure range	Supports diverse irrigation applications, from low pressure drips, to high pressure sprinklers
Minimal head loss	Enhances water flow efficiency and reduces energy costs in irrigation systems
Rapid response design	Quickly adjusts to pressure and flow changes, ensuring reliable water delivery
Angle valve option	Allows more flexible installation in tight or complex piping configurations
Control trim with self-flushing filter	Reduces periodic inspection /cleaning /maintenance, saving on labor costs

## General Operation

### Valve Closed Position

#### Hermetic Shut-Off: Secure Drip-Tight Sealing for Total Isolation & Absolute Confidence

When upstream pressure is directed into the control chamber, Eliptix's specialized elliptical diaphragm is pressed firmly against the valve seat. This precision engineering ensures a hermetic, drip-tight seal that maintains its integrity even under fluctuating line conditions. The result is a highly dependable solution for secure system isolation and the long-term protection of critical infrastructure.

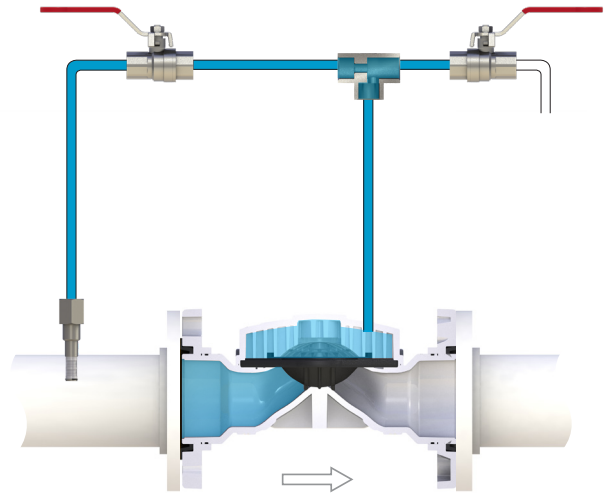

### Valve Open Position

#### Peak Performance: Optimum Flow Efficiency for Minimal Resistance & Maximum Delivery

By venting pressure from the control chamber, the internal line pressure lifts the diaphragm into a fully open position. The signature Eliptix design creates a streamlined, unobstructed flow path specifically engineered to minimize head loss. This superior hydraulic profile significantly reduces energy costs while maximizing total delivery capacity.

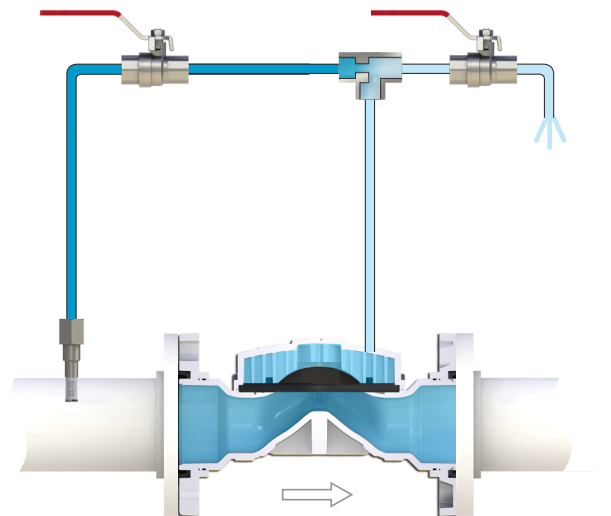

### Regulation State

#### Dynamic Regulation: Precision & Rapid Response for Stability Under Any Condition

The Eliptix excels in dynamic regulation by precisely balancing pressure within its unique, low-volume control chamber. This compact architecture enables a near-instantaneous response to fluctuations in pressure and flow, allowing the valve to throttle with fine precision. The result is unwavering stability at every set-point and smooth, reliable performance across the entire flow spectrum—from zero to maximum capacity.

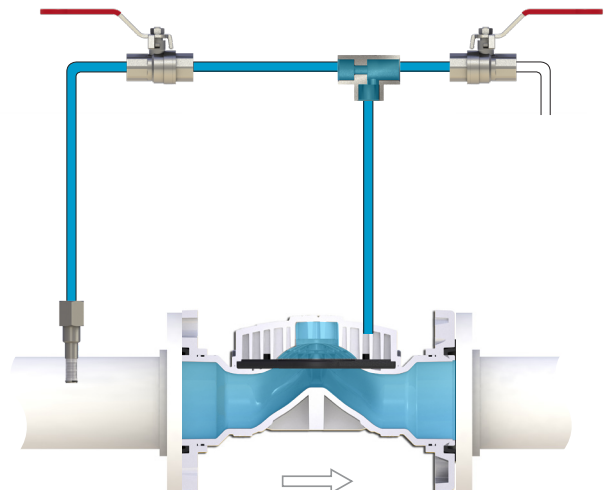

## Technical Specifications

Size Range		DN40-DN200 / 1½"-8"
Working Pressure		10 bar / 145 psi
Max. Water Temperature		55° C / 130° F
End Connections		Grooved
		Threaded BSP / NPT
		Flanged Universal
Construction Materials	Body & Cover	Glass Reinforced Polyamide, Polypropylene
	Spring	Stainless Steel 302
	Diaphragm	NR / EPDM
	Fittings & Control Trim Devices	Glass Reinforced Polyamide, Polypropylene
	Control Trim Tubes	Polyethylene

\* Other options are available upon request.

## Parts List

No.	Part
1	Bolts Kit
2	Bonnet
3	Spring
4	Spring Seat
5	Diaphragm
6	Insert
7	Valve Body



## ➤ Dimensions and Weight

### Straight Threaded Models

Valve Size	DN40 (1½")		DN50 (2")		DN50 (2"S)		DN65 (2.5")		DN80 (3")		DN80 (3"S)		DN100 (4")	
Dim.	mm	inch	mm	inch	mm	inch	mm	inch	mm	inch	mm	inch	mm	inch
L	180	7.09	190	7.48	237	9.33	259	10.2	277	10.91	310	12.2	350	13.78
H	105	4.13	108	4.25	105	4.13	112	4.41	121	4.76	168	6.61	181	7.13
W	140	5.51	140	5.51	166	6.54	166	6.54	166	6.54	240	9.45	240	9.45
Weight	kg	lbs	kg	lbs	kg	lbs	kg	lbs	kg	lbs	kg	lbs	kg	lbs
	0.7	1.4	0.7	1.4	1.3	2.6	1.5	3	1.5	3	3.6	7.3	3.9	7.9

### Straight Flanged Models

Valve Size	DN80 (3")		DN80 (3"S)		DN100 (4")		DN150 (6")		DN200 (8")	
Dim.	mm	inch	mm	inch	mm	inch	mm	inch	mm	inch
L	282	11.1	315	12.4	356	14.02	424	16.69	502	19.76
H	198	7.8	208	8.19	228	8.98	258	10.16	340	13.39
W	198	7.8	240	9.45	240	9.45	339	13.35	340	13.39
Weight	kg	lbs	kg	lbs	kg	lbs	kg	lbs	kg	lbs
	3.3	6.7	4.3	8.7	7	13.6	15	30.4	18	36.4

### Straight Grooved Models

Valve Size	DN80 (3")		DN80 (3"S)		DN100 (4")	
Dim.	mm	inch	mm	inch	mm	inch
L	277	10.91	310	12.2	350	13.78
H	112	4.41	154	6.06	166	6.54
W	166	6.54	240	9.45	240	9.45
Weight	kg	lbs	kg	lbs	kg	lbs
	1.3	2.6	3.2	6.5	3.5	7.1

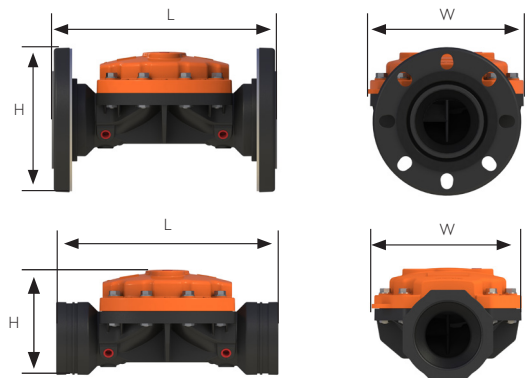

### Straight Solvent Welding Models

Valve Size	DN50 (2"S)	
Dim.	mm	inch
L	277	10.91
H	112	4.41
W	166	6.54
Weight	kg	lbs
	1.6	3.2

## Dimensions and Weight

### Angled Threaded Models

Valve Size	DN50 (2" S)		DN80 (3")	
	mm	inch	mm	inch
L	210	8	230	8
F	148	5.8	168	6.6
W	165	6.5	165	6.5
Weight	kg	lbs	kg	lbs
	1.5	3.3	1.7	3.7

### Angled Grooved

Valve Size	DN80 (3")	
Dim.	mm	inch
L	224	9
F	162	6.4
W	165	6.5
Weight	kg	lbs
	1.6	3.5

### Angled Flanged

Valve Size	DN80 (3")	
Dim.	mm	inch
L	264	10
F	165	6.5
W	199	8
Weight	kg	lbs
	2.9	6.4

All product weights & dimensions are approximate, due to the differences in flange standards, materials and variable accessories.

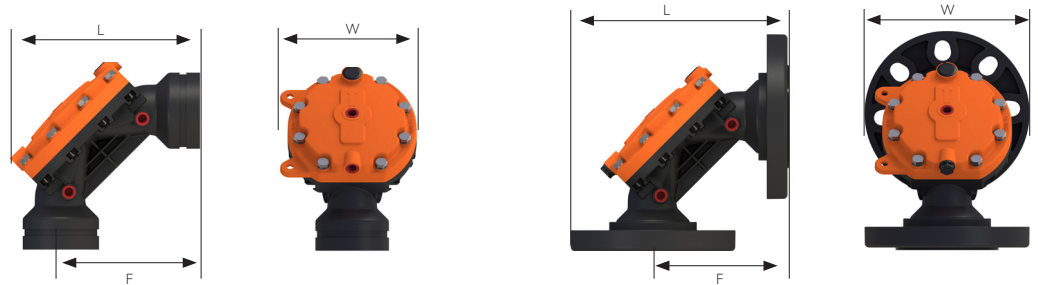

## Head Loss Chart

### Straight Valves

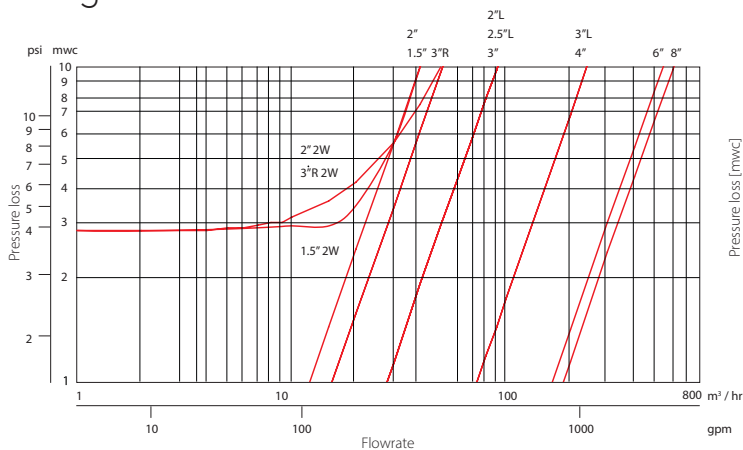

### Angle Valves

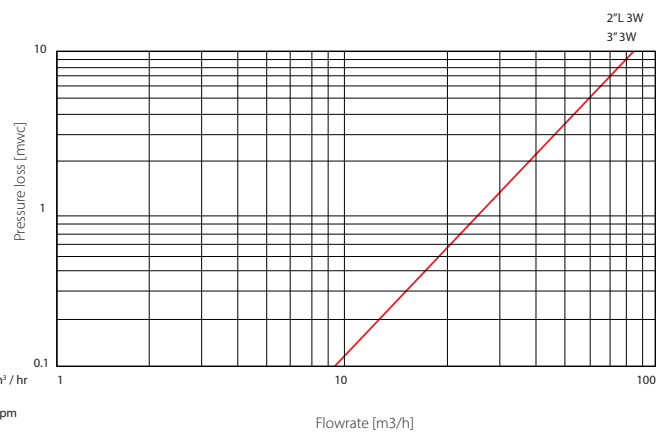

### Hydraulic Performance

#### Straight Grooved Models

Valve Size		DN40 (1½")	DN50 (2")	DN50 (2"S)	DN65 (2.5")
Control Chamber Volume	cm <sup>3</sup>	94	94	150	150
	in <sup>3</sup>	5.74	5.74	9.15	9.15
Working Pressure Range	bar	0.5-10	0.5-10	0.4-10	0.4-10
	psi	7.3-145	7.3-145	5.8-145	5.8-145
Flow Coefficient	Kv	40	51	91	91
	Cv	46	59	105	105

Valve Size		DN80 (3")	DN80 (3"S)	DN100 (4")	DN150 (6")	DN200 (8")
Control Chamber Volume	cm <sup>3</sup>	150	400	400	2300	2300
	in <sup>3</sup>	9.15	24.41	24.41	140.35	140.35
Working Pressure Range	bar	0.4-10	0.4-10	0.4-10	0.4-10	0.4-10
	psi	5.8-145	5.8-145	5.8-145	5.8-145	5.8-145
Flow Coefficient	Kv	91	240	240	542	607
	Cv	105	277	277	627	702

#### Angled Grooved Models

Valve Size		DN50 (2"S)	DN80 (3")
Control Chamber Volume	cm <sup>3</sup>	150	150
	in <sup>3</sup>	9	9
Working Pressure Range	bar	0.4-10	0.4-10
	psi	5.8-145	5.8-145
Flow Coefficient	Kv	86	86
	Cv	99	99



## Control Functions

### ELIPTIX R-20 EL (3W)

Weir-type, Elliptical-shaped Diaphragm  
3-way, Electric Operated Control Valve

---



### ELIPTIX R-20 M (3W)

Weir-type, Elliptical-shaped Diaphragm  
3-way, Manual Control Valve

---



### ELIPTIX R-20 QR (3W)

Weir-type, Elliptical-shaped Diaphragm  
3-way, Quick Pressure Relief Control Valve

---



### ELIPTIX R-20 PR (2W)

Weir-type, Elliptical-shaped Diaphragm  
2-way, Pressure Reducing Control Valve

---



### ELIPTIX R-20 PR/M (3W)

Weir-type, Elliptical-shaped Diaphragm  
3-way Pressure Reducing Control Valve, with Manual  
Override

---



### ELIPTIX R-20 PS/M (3W)

Weir-type, Elliptical-shaped Diaphragm  
3-way Manual Override, Pressure Sustaining Control Valve

