



68F-DE\EL\PTMR

Deluge Valve
Electrically or Pneumatically Actuated
Manually-Reset

IOM

Installation • **O**peration • **M**aintenance



Installation, Operation & Maintenance

This document specifies the operating concept of OCV deluge valve model 68F-X-DEVELPTMR (X refers to valve size in Inch), FM approved when trimmed per the following technical data sheet

Please review the safety instructions at the end of this document prior to commissioning the valve for use

DELUGE VALVE MODEL 68F-DE\EL\PTMR General Description

OCV deluge valve model 68F-X-DE\EL\PTMR is a globe\weir-type hydraulic valve, actuated automatically or manually. The valve is mounted on the upstream side of a fire-suppression sprinkler system, preventing flow into the system in the “set” condition.



Operating pressures

- Pressure rating up to 25 bar \ 375 psi
- Minimum system water pressure 1.5 bar \ 22 psi
- Pneumatic air (or nitrogen gas) pressure requirement - see **Pilot-line pressure Vs. Upstream supply pressure chart (Design Data)**

FM approved working pressures

- 2” - 8” : 25 bar \ 375 psi

Available end connections

- Flanged: 2” – 8”
- Grooved: 2” – 8”

Available body & cover and trim materials

Standard Materials			
Body & Cover	Trim components	Tube / Tube Fittings	Diaphragm
Ductile Iron ASTM A536	Bronze/Brass	Copper / Bronze/Brass	NR
Other materials available			
Stainless Steel ASTM A351 CF8M	Nickel Plated Brass	SST316	Neoprene
Cast Steel ASTM A216 WCB	SST316	Super Duplex	EPDM
Cast Steel ASTM A352 LCB	Super Duplex	MONEL®	NBR
Ni-Al Bronze ASTM B148 gr.C95800	MONEL®	Cu-Ni 90/10	
Duplex Stainless Steel	Aluminum-Bronze		
Super Duplex Stainless Steel			
Titanium			

Installation, Operation & Maintenance

DELUGE VALVE MODEL 68F-DE\EL\PTMR

General Description (refer to figures 2,3&4)

“Set” condition:

1. In the “set” condition, the deluge valve is held closed drip tight by the upstream water pressure, trapped in the valve's control chamber. The water pressure enters the control chamber through the priming line ball valve [b1], a Y-type strainer [c], a check valve [d], a PTMR (Pneumatic Touch Manual Reset) latching relay [r] and a restrictor [e1].

“Fire” conditions and deluge valve actuation:

1. The deluge valve is actuated when a 2/2-way normally closed solenoid valve [a] is energized (or the coil of a continuously energized ED 100% normally open solenoid is de-energized for SIL 3-4 rated systems) or when pressure in the dry (pneumatically-pressurized) pilot-line drops.
2. In case of failure of the automatic actuation system, manual emergency actuation is possible.
3. Deluge valve actuation causes the PTMR latching relay [r] to latch open, allowing the water to drain from the valve's control chamber. Once actuated, the valve must be manually reset momentarily pressing the PTMR's latching relay [r] reset port.

Manual emergency actuation:

1. The manual emergency actuation valve [b2] may be located inside a metal box or over a panel. If in a box – first lift the cover - and turn the handle as shown on the plaque in the box.

Closing the deluge valve is possible only after:

1. Shutting the isolation valve [i1] (If the priming line is connected to the upstream of the isolation valve).
2. De-energizing the solenoid [a].
3. Restoring pressure in the dry (pneumatically-pressurized) pilot-line.
4. Verifying the manual emergency actuation ball valve [b2] is closed.
5. Manual-resetting by momentarily pressing the PTMR's latching relay [r] reset port.

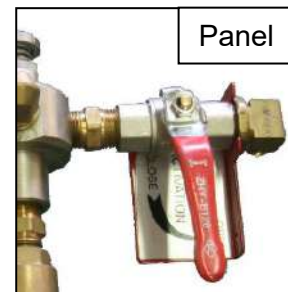

DELUGE VALVE MODEL 68F-DE\EL\PTMR

Pre-Installation (refer to figures 2,3&4)

1. The deluge valve is factory trimmed for both vertical (with the upstream positioned at the bottom) and horizontal installation - out of the box, requiring no changes or tooling.
2. Sufficient space for maintenance should be left around the deluge valve.
3. A manual isolating valve (supplied by 3rd party) should be assembled upstream of the deluge valve for maintenance purposes.
4. Flush the pipelines prior to valve installation. If anti-corrosion, anti-freeze or any other type of additives are to be used, please consult OCV FP division concerning potential damage to the valve and its components.
5. The deluge valve should be positioned in such a way that allows easy access to the emergency manual actuation valve [b2].
6. The priming control trim's ball valve [b1] should be connected to the main supply pipe upstream of the isolating valve [i1], unless factory preassembled with the priming line ball valve [b1] pre-connected to the valve's upstream port.
7. Verify that all sprinklers on the dry (pneumatically-pressurized) pilot-line, are intact and replace any broken sprinklers if necessary.
8. Connect the dry (pneumatically-pressurized) pilot-line to the pilot-line's isolation ball valve [b6].
9. Connect the pneumatic air (or nitrogen gas) supply unit to the check valve [d1] or to the PPCS' (Pneumatic Pressure Control System) air supply – inlet isolating valve [b8] (if the PPCS is supplied).
10. Verify minimum system water pressure and supervisory pneumatic pressure (see **Operating Pressures and Pilot-line pressure Vs. Upstream supply pressure chart**).
11. Verify that the manual emergency actuation valve [b2] and the pilot-line's test ball valve [b7] are closed.
12. Wire all releasing and detection components to the F&G panel according to the wiring diagrams provided by the manufacturers of the F&G panel and the electrical components.
13. Connect the water motor alarm (if supplied) to the alarm test trim's isolation ball valve [b5].
14. A drain for the water drained during the valve's test & working procedures should be prepared. The drain valves [j1, j2] (if supplied), the outlet pipes of the PTMR latching relay [r] and the manual emergency actuation valve [b2] should be drained appropriately.

DELUGE VALVE MODEL 68F-DE\EL\PTMR

Pre-Installation (refer to figures 2,3&4)

Fig. 1- General layout

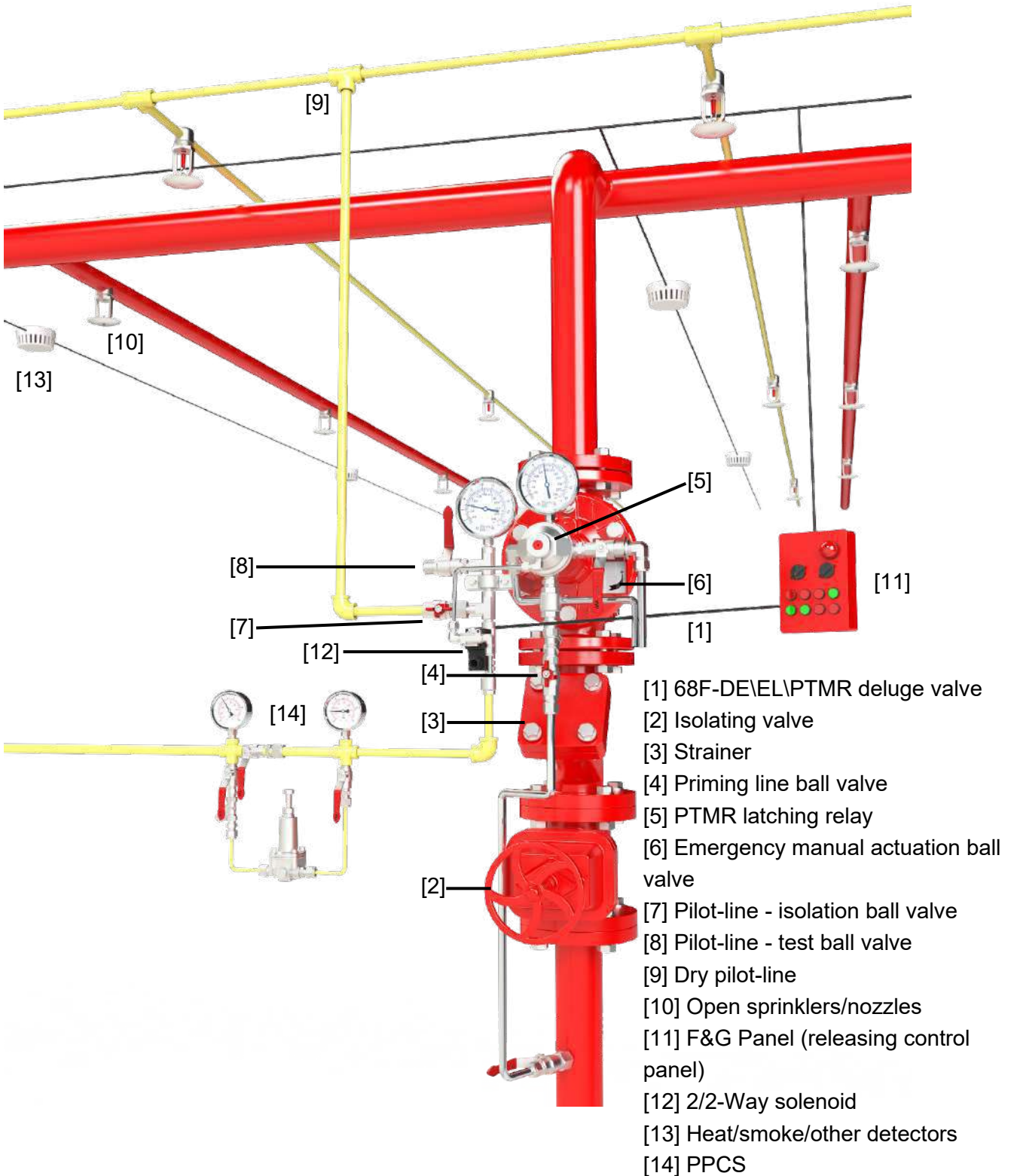

DELUGE VALVE MODEL 68F-DE\EL\PTMR **System & Design Requirements (refer to figures 2,3&4)**

Note: For systems which might be exposed to extreme low temperatures, which are lower than the dew point of the supervisory air (or nitrogen gas) supply, moisture may freeze to form ice that may block and impair the proper operation of the supervisory system. To avoid this, supervisory air (or nitrogen gas) should be supplied from refrigerated areas at the lowest system's temperature.

Temperature

If freezing conditions are expected, prior to being exposed, the control valve should be properly drained and dried to avoid ice formation which may cause damage to the valve and trim. Consult OCV for further technical support relating to extreme weather conditions.

Electrical requirements

The deluge valve is controlled and actuated by a detection system comprised of electrical components such as heat/smoke/other detectors, and/or electric manual pull stations, which are wired to a F&G panel (Fire & Gas releasing control panel).

All releasing and detection components should be wired to the F&G panel, according to the wiring diagrams provided by the manufacturers of the F&G panel and the electrical components.

The owner should consult local/national authorities having jurisdiction regarding installation criteria of the electric circuitry.

Pneumatic air (or nitrogen gas) supply system

The required pneumatic air (or nitrogen gas) pressure, as a function of the upstream water supply pressure, is shown on the **Pilot-line pressure Vs. Upstream supply pressure chart**. Pneumatic air (or nitrogen gas) pressure should be regulated by an air compressor or by OCV' PPCS.

DELUGE VALVE MODEL 68F-DE\EL\PTMR

Fig. 2- System P&ID

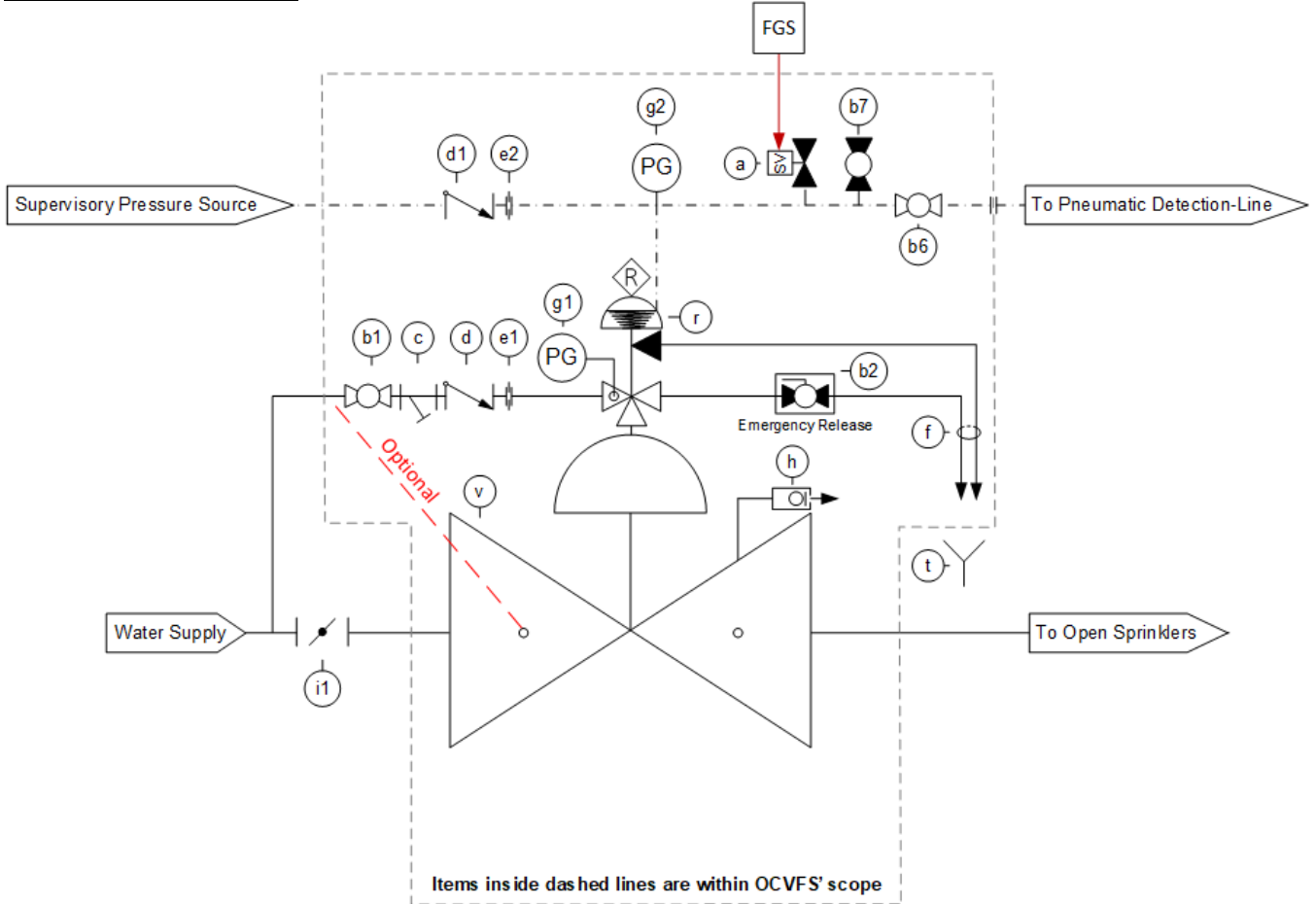

* When a PPCS is supplied, check-valve [d1] & restrictor [e2] are redundant (not supplied)

Integral System items	
Item #	Description
v	Hydraulic valve
a	2/2-Way solenoid
b1	Priming line ball valve
b2	Emergency manual activation valve
b6	Pilot-line - isolation ball valve
b7	Pilot-line - test ball valve
c	Y-Type strainer
d, d1	Check valve
e1, e2	Restrictor
f	Drain tube
g1, g2	Pressure gauge
h	Drip valve
r	Pneumatic latching Manual Reset Relay

Optional System items	
Item #	Description
	Alarm Test Trim
	Pneumatic Pressure Control System
	See Optional Add-Ons

Out Of Scope items	
Item #	Description
i1	Isolating valve
t	Drain funnel

Installation, Operation & Maintenance

DELUGE VALVE MODEL 68F-DE\EL\PTMR

Fig. 3 - Alarm Test Trim & Optional Add-Ons

Alarm Test Trim Integral Items	
Item #	Description
b3	Alarm trim - test ball valve
b4	Alarm trim - drain\purge ball valve
b5	Alarm trim - isolation ball valve

Optional Add-Ons	
Item #	Description
j1, j2	Upstream, Downstream drain valve
g3	Cover pressure gauge
g4	Downstream pressure gauge
p1	Cover pressure switch low - water
p3	Downstream pressure switch high - water
i	Water motor alarm
l	Position Indicator
ZSO	Proximity switch - open
ZSC	Proximity switch - closed
s	Spring

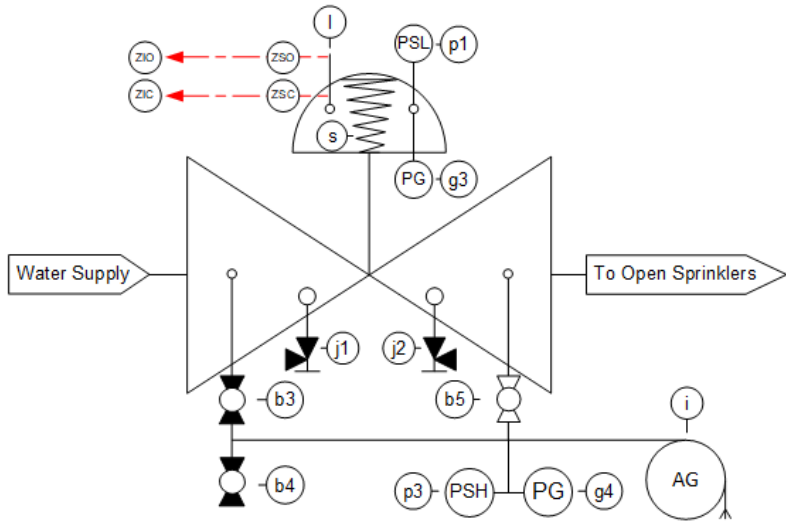

* Optional add-ons may be supplied independently, without the alarm test trim's integral items

Fig. 4 - PPCS (Pneumatic Pressure Control System) P&ID

PPCS (Optional) - System items	
Item #	Description
b8	Air supply - Inlet isolating valve
b9	Air supply - Outlet isolating valve
b10	Air supply - Override valve
c	Y-Type strainer
d	Check valve
e3	Restrictor
n1	68-410 Pressure reducing pilot
T	Air accumulator reservoir (Optional)

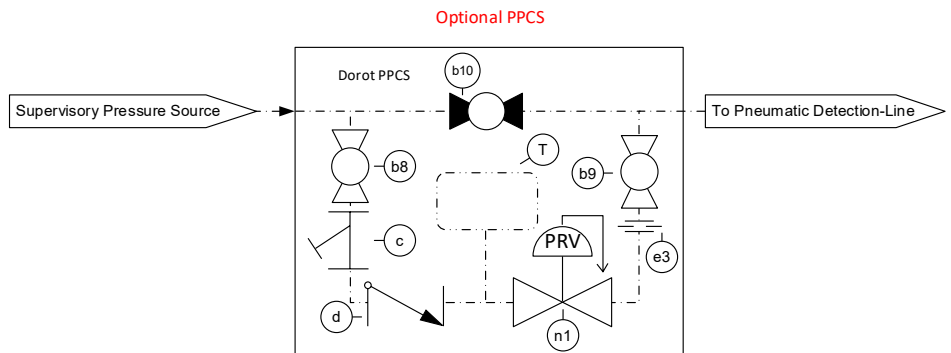

Pneumatic trim without PPCS System items	
Item #	Description
d1	Check valve
e2	Restrictor
p2	Pressure Switch Low - air (Optional)

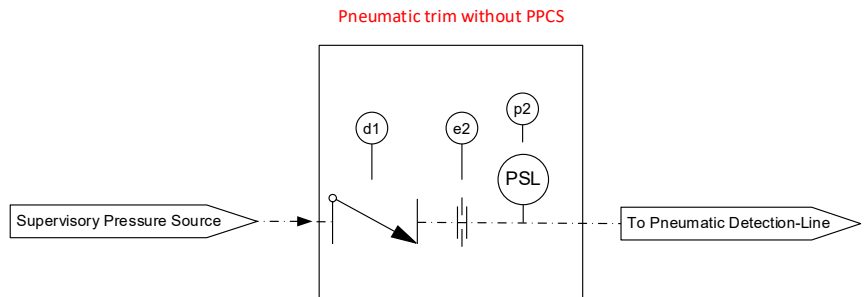

DELUGE VALVE MODEL 68F-DE\EL\PTMR

Control Trim Connection (refer to figures 2,3&4)

Note: if using an external pressure source, it should be at a pressure equal or higher than the maximal upstream pressure.

1. The deluge valve's control chamber is connected to a pressure source upstream of the isolating valve [i1], unless factory preassembled with the priming control trim pre-connected to the valve's upstream port].
2. The upstream control trim includes the following items:
 - Priming line ball valve [b1].
 - Y-Type strainer [c].
 - Check valve [d].
 - PTMR (pneumatic latching manual-reset relay) [r].
 - Restrictor [e1].
3. The PTMR latching relay [r] has two positions:
 - 'Closed' - prevents draining of the deluge valve's control chamber.
 - 'Latched-Open' - allows draining of the control chamber, latching open the deluge valve. Manual-resetting is accomplished by momentarily pressing the PTMR's latching relay [r] reset port.
4. The 2/2-way N.C. solenoid [a] is connected to the F&G panel. When energized, the 2/2-way N.C. solenoid [a], releases the pressure from the control chamber, opening the deluge valve.

Note: Ball valves [b3-b5] are part of the alarm test trim and supplied upon request (optional). Ignore any reference to them if they do not exist.

5. A water motor alarm [i] may be connected to the deluge valve via an optional alarm test trim. The alarm test trim consists of:
 - Ball valve [b5], which is normally-open.
 - Ball valve [b3], which is normally-closed and allows testing the alarm without opening the deluge valve.
 - Ball valve [b4], which is normally-closed and allows draining the alarm test trim and purging it from corrosive fluids if necessary.
6. A low-pressure drip valve (relief valve) [h], is mounted on a downstream port of the deluge valve, as a safety device against faulty sealing of the deluge valve, which may be caused by foreign objects or unclean water. The drip valve allows small quantities of water to be drained from the system but shuts instantly when the deluge valve is actuated and high pressure is present.
7. Upstream and downstream ports on the deluge valve allow connecting a drain valve [j1, j2] (optional).
8. Pressure gauges allow visual inspection of the upstream [g1], pilot-line [g2], control chamber [g3] (optional) and downstream [g4] (optional) pressures.
9. Pressure switches (optional) may be connected to the valve's control chamber [p1], the pilot-line [p2] or to the valve's downstream port [p3], allowing an electric indication of dropping air pressure or opening of the deluge valve.

DELUGE VALVE MODEL 68F-DE\EL\PTMR **Commissioning Procedure** (refer to figures 2,3&4)

Note: The following procedures should be carried out as written, in addition to relevant NFPA demands or other local applicable regulations.
It is recommended that the installation and adjustment be performed by qualified personnel.

Note: The steps listed below should be performed when initially placing the valve in service, after a test of the fire protection system has been carried out or after the system has operated, following a fire.

Note: Drain valves [j1, j2,] are supplied upon request (optional). Ignore any reference to them if they do not exist

Note: If water should not be allowed into the system during commissioning or tests, a downstream drain valve should be installed. Open this drain valve prior to resetting the valve and close it after the valve has been commissioned.

Drain the system:

1. Close the isolating valve [i1] and the priming line ball valve [b1].
2. Open existing drain valves [j1, j2,] and all auxiliary drains in the system.
3. Once water has stopped discharging, close existing drain valves and all auxiliary drains in the system, except for the upstream drain valve [j1].

Reset the valve to its “set” position:

1. Follow Pre-Installation procedure (see **Pre-Installation**).
2. If the priming control trim's ball valve [b1] is factory preassembled with the priming line ball valve [b1] pre-connected to the valve's upstream port, slowly open the isolating valve [i1]. Disregard this stage if the priming control trim's ball valve [b1] is connected to a pressure source upstream of the isolating valve [i1].
3. Reset the electric detection system in accordance with the manufacturer's instructions to de-energize the 2/2-way N.C. solenoid [a].
4. Open the pilot-line isolation ball valve [b6] and momentarily press the PTMR's latching relay [r] reset port to allow the pneumatic pressure to build up.
5. Open the priming line ball valve [b1] and allow pressure to build up in the deluge valve's control chamber.
6. Crack open the manual emergency actuation valve [b2] and allow trapped air to vent from the deluge valve's control chamber.
7. Immediately close the manual emergency actuation valve [b2] once all air has been vented from the deluge valve's control chamber.
8. Momentarily press the PTMR's latching relay [r] reset port allow pressure to build up in the deluge valve's control chamber.
9. Inspect all drain tubes and verify there are no leaks.
10. Verify there is no water leaking from the drip valve [h]. If leaks occur determine the cause of the leak and correct it before moving to the next step.
11. If the priming control trim's ball valve [b1] is connected to a pressure source upstream of the isolating valve [i1], slowly open the isolating valve [i1]. Disregard this stage if the priming control trim's ball valve [b1] is factory preassembled with the priming line ball valve [b1] pre-connected to the valve's upstream port.
12. Close the upstream drain valve [j1] when water starts flowing through it.
13. Verify the isolating valve [i1] is completely open.
14. If no leaks occur, the deluge valve is now set for service.

DELUGE VALVE MODEL 68F-DE\EL\PTMR **System Testing Procedure (refer to figures 2,3&4)**

Note: As some of the tests may sound an alarm, it is necessary to alert the owner, local personnel and local fire-fighting authorities before these tests are carried out.

Note: The PSLs (Bonnet Pressure Switch Low – Water [p1], Pilot-line Pressure Switch Low – air [p2]), the PSH (Pressure Switch High - water [p3]) and the WMA (Water Motor Alarm [i]) are supplied upon request (optional). Ignore any reference to them if they do not exist.

Note: Ball valves [b3-b5] are part of the alarm test trim and supplied upon request (optional). Ignore any reference to them if they do not exist.

Manual emergency actuation test:

1. Open the manual emergency actuation valve [b2]. Verify the deluge valve has tripped open.
2. To reset the deluge valve, refer to “Commissioning Procedure”.

Automatic actuation test:

1. Gradually open the pilot-line’s test ball valve [b7] to simulate the rupture of sprinklers or energize the 2/2-way N.C. solenoid [a] via the F&G panel, according to the instructions provided by the F&G panel manufacturer. Verify the deluge valve has tripped open.
2. Verify the pressure switches [p1, p3] have indicated that the valve has tripped open and/or air pressure in the dry (pneumatically-pressurized) pilot-line has dropped.
3. To reset the deluge valve, refer to “Commissioning Procedure”.
4. Gradually close the pilot-line’s test ball valve [b7].
5. To reset the deluge valve, refer to “Commissioning Procedure”.

Alarm test trim check (if supplied):

1. Close ball valve [b5].
2. Open ball valve [b3]. Water will enter the WMA (Water Motor Alarm) and the PSH (Pressure Switch High - water) [p3]. The PSH [p3] will signal and indicate that water pressure is rising downstream and the water motor alarm [i] will sound.
3. Close ball valve [b3] and drain the alarm test trim through ball valve [b4]. Close this valve when water stops flowing.

DELUGE VALVE MODEL 68F-DE\EL\PTMR

Pilot and relay connection

PTMR (Pneumatic Touch Manual-Reset) latching relay

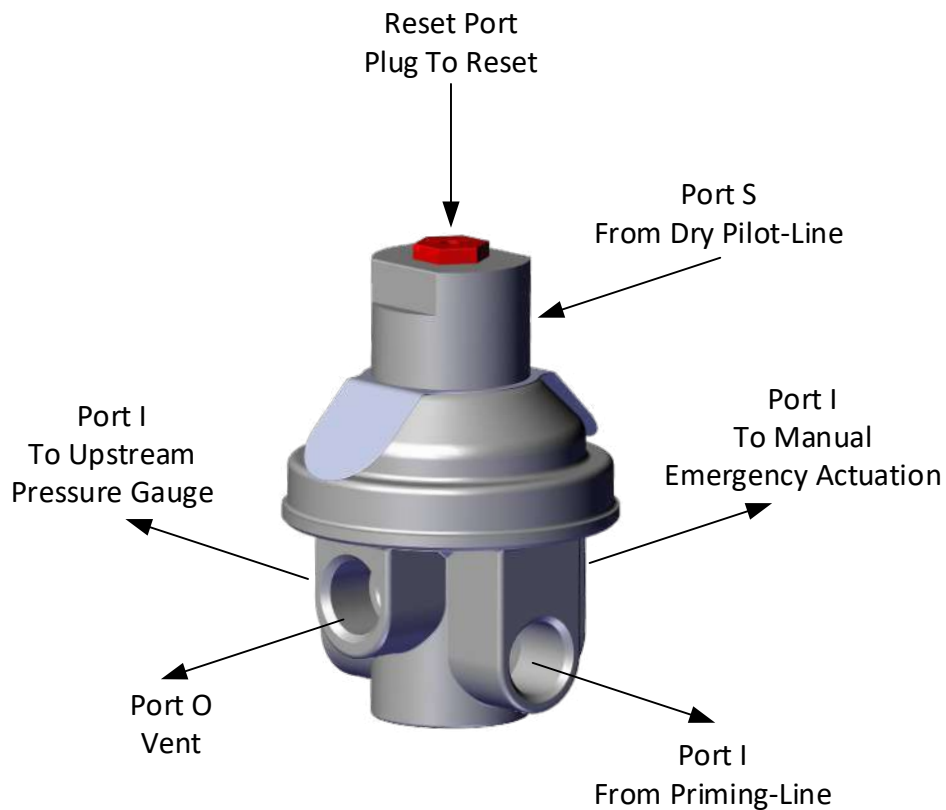

DELUGE VALVE MODEL 68F-DE\EL\PTMR

Recommended Periodical Check-up and Maintenance

(refer to figures 2,3&4)

Note: The owner of the valve is responsible for the setting, inspecting, routine testing and the maintenance of the valve as written, in compliance with the applicable standards of the National Fire Protection Association (e.g., NFPA 25), in addition to standards of local authorities having jurisdiction.

Before closing a fire protection system control valve for maintenance or periodical testing, permission to shut down the affected fire protection systems must be obtained from the proper authorities. As per FM 1011, 1012, 1013, fire patrols should be established in the affected areas and all personnel affected by this action should be notified.

It is recommended that all tests and maintenance procedures be carried out by qualified personnel.

Note: As some of the tests may sound an alarm, it is necessary to alert the owner, local personnel and local fire-fighting authorities before these tests are carried out.

Annual operation test

Proper operation of the control valve during fire conditions should be verified at least once a year. The automatic actuation test which simulates the rupture of sprinklers due to a fire event is described in the “System Testing Procedure” under “Automatic actuation test”.

Quarterly alarm test trim operation test

Testing the alarm test trim should be performed on a quarterly basis. The alarm test trim check is described in the “System Testing Procedure” under “Alarm test trim check”.

Taking the system out of service

Taking the system out of service should only be done under authorization of the appropriate authority having jurisdiction.

When taking the system out of service, the following steps should be taken:

1. Close the isolating valve [i1].
2. Shut off the pneumatic air (or nitrogen gas) supply.
3. Close the priming line ball valve [b1].
4. Open all applicable drain valves [j1, j2,] and all auxiliary drains in the system and allow the system to de-pressurize.
5. Silence all alarms (optional).
6. Relieve all excess pressure from the deluge valve’s control chamber by opening the manual emergency actuation valve [b2].

DELUGE VALVE MODEL 68F-DE\EL\PTMR

Design Data

Head loss chart

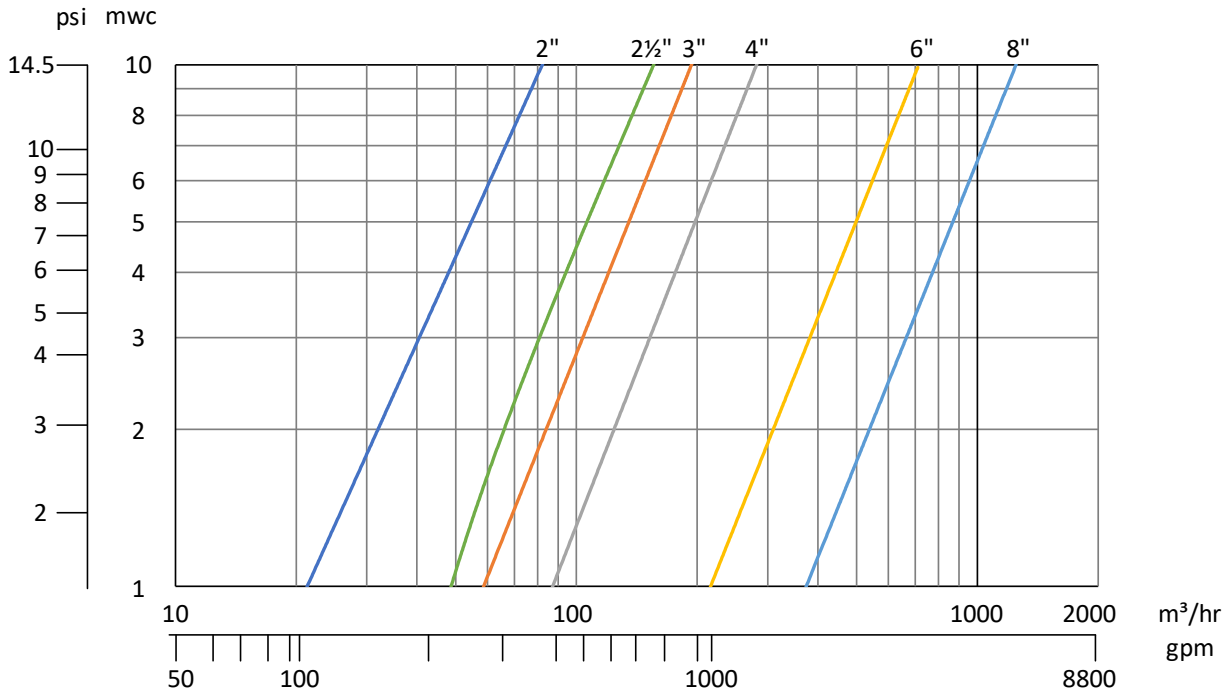

Hydraulic characteristics

Valve Size		50 (2")	65 (2½")	80 (3")	100 (4")	150 (6")	200 (8")
K_v	m ³ /hr @ 1	80	150	200	300	700	1200
C_v	gpm @ 1 psi	92	173	231	347	809	1387
K Factor	-	1.57	1.3	1.64	1.78	1.66	1.78
Equivalent Pipe Length @ C_{HW} = 120	meters	4	4	6	9	13	20
	feet	12	12	21	29	44	66
Control Chamber Displacement Volume	Liters	0.18	0.3	0.3	0.5	2	4.8
	Gallons	0.05	0.08	0.08	0.13	0.53	1.27

DELUGE VALVE MODEL 68F-DE\EL\PTMR Design Data

Pilot-line pressure Vs. Upstream supply pressure chart (Design Data)

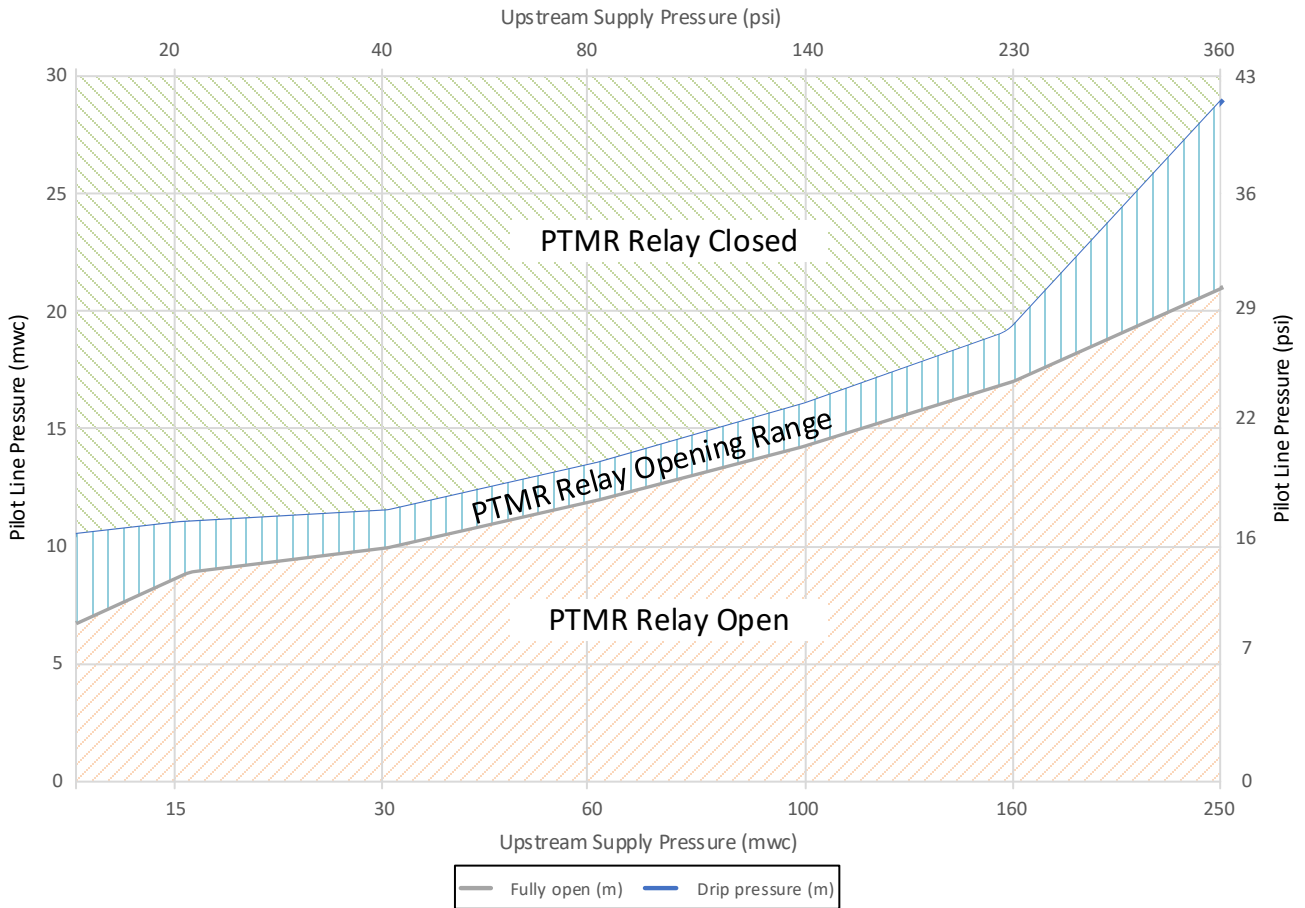

DELUGE VALVE MODEL 68F-DE\EL\PTMR

Operation Modes

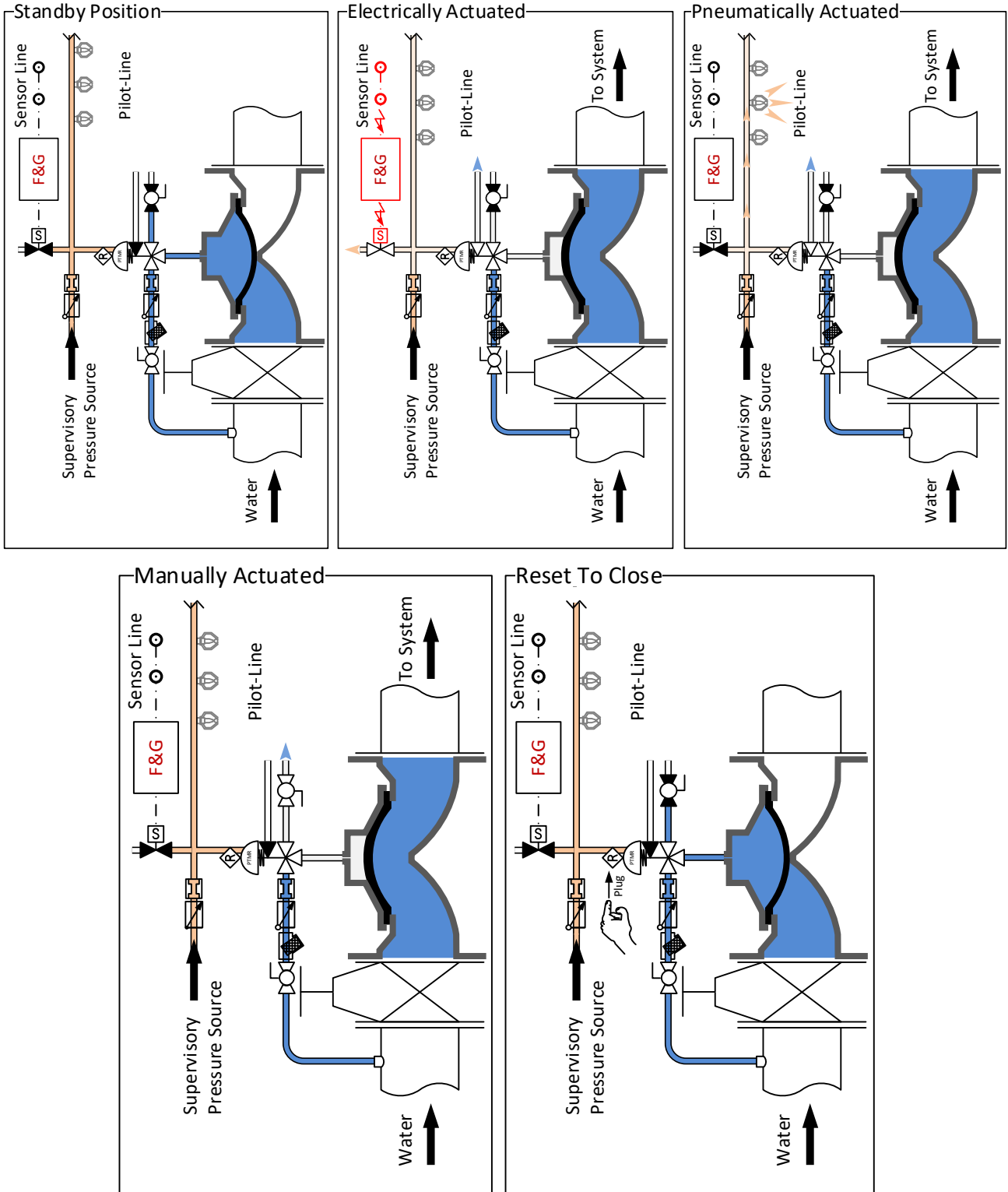

Installation, Operation & Maintenance

DELUGE VALVE MODEL 68F-DE\EL\PTMR Basic Valve Dimensions

Valve Size		50 (2")		65 (2½")		80 (3")		100 (4")		150 (6")		200 (8")		
		mm	inch	mm	inch	mm	inch	mm	inch	mm	inch	mm	inch	
Dimensions	68F Flanged	L	245	9 5/8	334	13 3/16	334	13 3/16	384	15 3/16	480	18 7/8	600	23 5/8
		H	178	7	251	9 7/8	295	11 5/8	292	11 1/2	368	14 1/2	470	18 1/2
		R	83	3 5/16	96	3 7/8	100	3 7/8	115	4 5/8	140	5 1/2	183	7 3/16
		W	173	6 7/8	236	9 5/16	236	9 5/16	267	10 1/2	327	12 7/8	402	15 13/16
		Weight kg/lbs	10 / 22		20 / 44		21 / 46		33 / 73		52 / 115		92 / 203	
	68F Grooved	L	245	9 5/8	334	13 3/16	334	13 3/16	384	15 3/16	480	18 7/8	600	23 5/8
		H	178	7	225	8 7/8	225	8 7/8	265	10 1/2	327	12 7/8	417	16 3/8
		R	83	3 5/16	67	2 5/8	67	2 5/8	89	3 1/2	100	3 7/8	130	5 1/8
		W	173	6 7/8	236	9 3/16	236	9 3/16	265	10 1/2	327	12 7/8	400	15 11/16
		Weight kg/lbs	4.5 / 10		16 / 35		16 / 35		23 / 51		38 / 84		44 / 97	

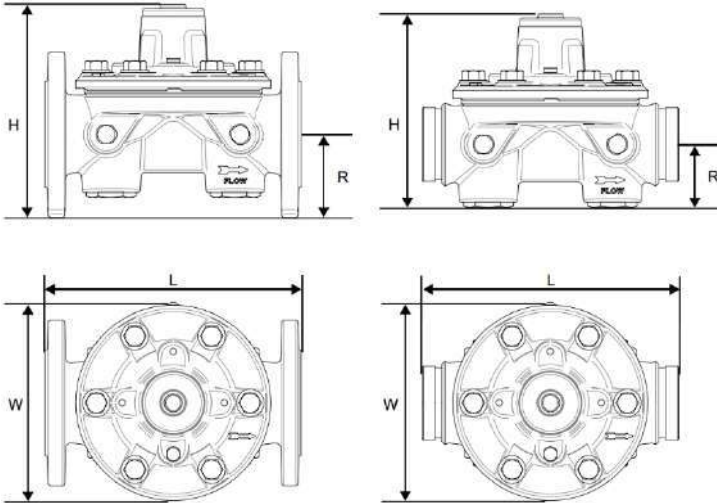

DELUGE VALVE MODEL 68F-DE\EL\PTMR Trim Dimensions

Size	50 (2")		65 (2½")		80 (3")		100 (4")		150 (6")		200 (8")	
Dimension	Inch	mm	Inch	mm	Inch	mm	Inch	mm	Inch	mm	Inch	mm
A	9 5/8	244	13 1/8	334	13 1/8	334	15 1/8	384	18 7/8	480	23 5/8	600
B	9	228	9	228	9	228	9	228	9 3/8	240	11 13/16	300
C	6 1/8	156	6 5/8	167	6 5/8	167	7 5/8	192	9 3/8	240	11 13/16	300
D	7	179	8 5/16	211	8 5/16	211	8 13/16	223.5	10 1/8	256	11 1/2	293
E	6 3/16	157	6 3/16	157	6 3/16	157	6 3/16	157	6 3/8	163	7 7/8	200
F	3 5/16	84	3 13/16	95.5	3 7/8	100	4 5/8	118	5 1/2	140	7 1/8	180
G	10 5/8	269	13 5/16	338	13 5/16	338	14 1/8	358	16 1/8	408	18 3/8	468

* Dimensions are approximate

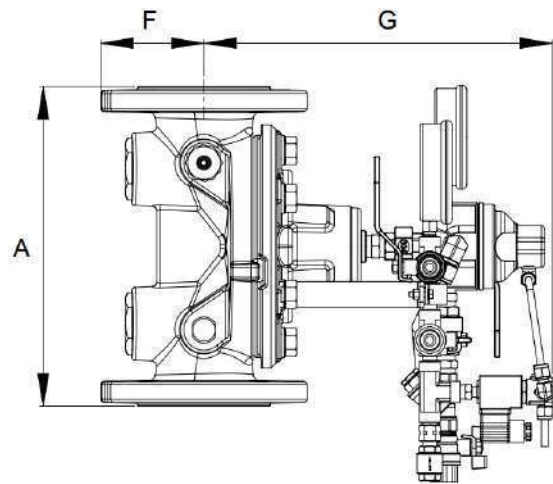
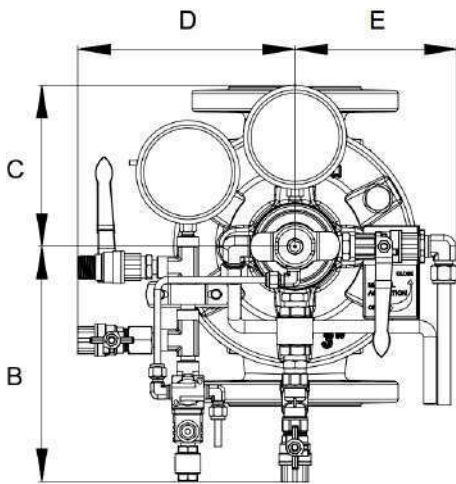

Installation, Operation & Maintenance

DELUGE VALVE MODEL 68F-DE\EL\PTMR **General Description** (refer to fig. 2 – System P&ID)

“Trouble” conditions

1.

Item number	Description	Alarms and visual indications	Corrective action
1	The valve has accidentally tripped	Water will flow out of the open sprinklers\nozzles. The PSH [p3] will signal and indicate that water pressure is rising downstream and the water motor alarm [i] will sound (if supplied)	Inspect the sprinklers on the dry pilot-line and verify they are intact
			Inspect the electrical circuit in the F&G panel
			Inspect the solenoid [a]
			Verify the emergency manual actuation valve [b2] is in its closed position
2	A pressure switch [p1, p2, p3] fails to give an electrical indication (if supplied)	Water will flow out of the open sprinklers\nozzles and/or air pressure will drop, with no indication from the pressure switches [p1, p2, p3]	Inspect the electrical circuit connections between the pressure switches [p1, p2, p3] and the F&G panel
			Check that water can flow freely into the pressure switches [p1, p2, p3] line connection
			Verify the pressure switches [p1, p2, p3] are set to the correct trip-point
3	The water motor alarm [i] does not sound (if supplied)	Water will flow out of the open sprinklers\nozzles but the water motor alarm [i] does not sound	Check for clogging in the alarm test trim's strainer
			Check that water can flow freely into the alarm test trim and into the WMA [i]
			Check for any physical obstructions in the WMA [i]
			Verify the alarm test trim's isolation ball valve [b5] is in its open position
4	Leakage through the main valve or in the trim	Moisture near trim components	Check for leaking trim components. Any leaks must be corrected
		The drip valve [h] is leaking (water is flowing to the downstream)	Check the drip valve [h] and observe if water is leaking through it. Check for clogging in the Y-type strainer [c]. If necessary, replace the main valve's diaphragm
		The PSH [p3] will signal and indicate that water pressure is rising downstream and the water motor alarm [i] will sound (if supplied)	

2. In case any other problems or difficulties have occurred, please contact OCV or its representatives in your geographical area.

Installation, Operation & Maintenance

Safety Instructions:

PLEASE NOTE

- Before using this product, read and understand the instructions.
- All procedures must be carried out by qualified personnel.
- Make sure that all applicable safety precautions have been taken in addition to these instructions.
- Read this manual along with all the provided data.
- Save these instructions for future reference.

Before disassembly of any accessory or component:

- All internal pressures must be relieved and all media drained from the system in accordance with all applicable procedures.
- Pressure must be 0 (zero) bar/psi.

Before Installation:

- **Flush the lines upstream of the valve. If anti-corrosion, anti-freeze or any other type of additives are used, please consult the documentation or OCV FP division concerning potential damage to the valve and its components.**
- Remove all external and internal packaging along with any temporary protective material.
- Carefully inspect the valve to ensure that no damage has occurred in transit or during subsequent handling.
- Ensure that the valve is the correct type and size and that the identification markings show that the material and pressure/temperature rating is suitable for the required service conditions.
- Read the installation instructions carefully and follow them.
- Ensure that the valve is lifted safely into position without damaging the valve.
- Ensure that the valve is installed so that it can be safely operated and maintained without putting any people at risk.
- Make sure that a firm footing is provided for the person installing the valve with adequate space around the valve to meet operating and maintenance requirements.
- Ensure that there is adequate lighting for valve installation.
- The valve can be installed in any position, but flow direction should match the engraved arrow on the bonnet.

Failure to follow the instructions set forth in this publication could result in property damage, personal injury, or death from hazards that may be associated with this type of equipment.