



Waterworks

Full-bore, Combination Air Valve Series

Description

A.R.I. D-46 is a full-bore, single-body, Combination Air Valve Series. Installed on liquid transmission systems, the Air Valve is designed to improve hydraulic operation by protecting the pipeline, increasing pipeline efficiency and reducing energy requirements. The Air Valve provides high-capacity air release and intake.

Installation

- Pump stations: after the pump and after the check valve
- Downstream and upstream of shut-off valves
- After deep-well pumps
- On long constant-sloped pipeline segments
- At peaks along the pipeline and at peaks relative to hydraulic gradient
- At end lines
- Before water meters
- On strainers and filters

Operation

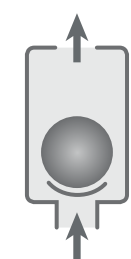

Air Discharge





Air Intake



Automatic
Air Release

Features and Benefits

Flow cross-sections	Equal to or greater than nominal port area
Single-body design	Easy to install and maintain, reduces downtime
Aerodynamic design	High-capacity air discharge, no premature closure
	Reduces water hammer impact
	Saves energy and increases system efficiency
Screen protected outlet	Prevents intrusion of insects and debris
Construction materials	Non-corrosive and durable
Automatic air release valve rolling seal	Leak-free sealing over a wide range of pressure differentials
Automatic air release valve orifice	High flow air release, lessens obstruction by debris
 ATEX certified air valves	ATEX certified air valves are optional by customer request. Certification is conditional upon the customer connecting the designated part on the product to a dedicated ground connection point.
 NSF/ANSI/CAN 61 Certified & Listed	For drinking water system component
	NSF/ANSI 372 Certified & Listed

Technical Specifications

Size range	2" - 6"
Sealing pressure range	1.45 - 250 psi 1.45 - 360 psi (D-46 STST 2" only) Testing pressure: 1.5 times maximum working pressure
Temperature	Maximum working temperature: 140° F Maximum intermittent temperature: 194° F
Metal valve coating	Fusion bonded epoxy coating in compliance with standard DIN 30677-2

Upon ordering, please specify: model, size, working pressure, thread / flange standard and type of liquid

➤ Valve Selection Options

US Models	A.R.I. D-46 STST 2" Stainless steel High flow combination air valve, rated to 250/360 psi
	A.R.I. D-46 STST NS 2" Non-slam Stainless steel High flow combination air valve, rated to 250/360 psi
	A.R.I. D-46 STST Vertical connection 2" Stainless steel High flow combination air valve, with vertical 2" outlet, rated to 250/360 psi
	A.R.I. D-46 High flow Ductile Iron combination air valve with an horizontal composite discharge outlet, rated to 250 psi
	A.R.I. D-46 NS Non-slam Ductile Iron combination air valve with an horizontal composite discharge outlet, rated to 250 psi
	A.R.I. D-46 Screen cover High flow Ductile Iron combination air valve with screen cover outlet, rated to 250 psi
	A.R.I. D-46 NS Screen cover Non -slam Ductile Iron combination air valve with screen cover outlet, rated to 250 psi
Valve connection	Threaded male BSPT/NPT (2"), flanged ends to meet various requested standards (2" - 6")
Standard materials	Cast Ductile Iron body
Optional add-on components	One-way, Out-only attachment, allows for air discharge only, prevents air intake Adjustable Non-slam disc, can also be optionally retrofitted on existing D-46 air valves.
Additional product configurations	SB Underground Air Valve System (for 2" & 3")

The valve installed under the air valve must be fully open to prevent damage or malfunction and ensure performance within the specifications of the air valve.

For complete installation instructions, please refer to the IOM document.

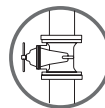

➤ Dimensions and Weight

Size	Dimensions (Inch)		Connections	Weight (Lbs.)	Orifice Area (Sq.In)		
	max. A	B			C	A / V	
Stainless Steel Models							
2" (50mm) THR	4.78	14.23	2" BSPT/ NPT F	9.24	3.26	0.02	
2" (50mm) FL	6.50	14.41	2" BSPT/ NPT F	10.12	3.26	0.02	
Ductile Iron Models - Elbow Outlet							
2" (50mm) FL	6.5	13.2	2" BSPT/ NPT F	16.1	3.04	0.023	
3" (80mm) FL	7.9	18.4	3" BSPT/ NPT F	19	7.79	0.021	
4" (100mm) FL	8.7	21.1	4" BSPT/ NPT F	40.1	12.17	0.021	
6" (150mm) FL	14.3	29.8	6" Grooved	96.1	28.29	0.023	
Ductile Iron Models - Screen Cover Outlet							
2" (50mm) FL	6.50	11.9	NA	14.96	3.0	0.023	
3" (80mm) FL	7.95	14.8	NA	28.16	7.8	0.021	
4" (100mm) FL	9.25	16.7	NA	37.4	12.2	0.021	
6" (150mm) FL	12.72	23.4	NA	94.6	28.3	0.023	

FL - Flanged THR - Threaded

NOTE

The cover assembly with the discharge elbow can be set in four directions. Dimension A in the picture and in the table shows the maximum product width. This width can be reduced by changing the cover direction.

All product weights are approximate, due to the differences in flange standards, materials and variable accessories.

Flow Charts Metal Models

Automatic Air Release Flow Rate

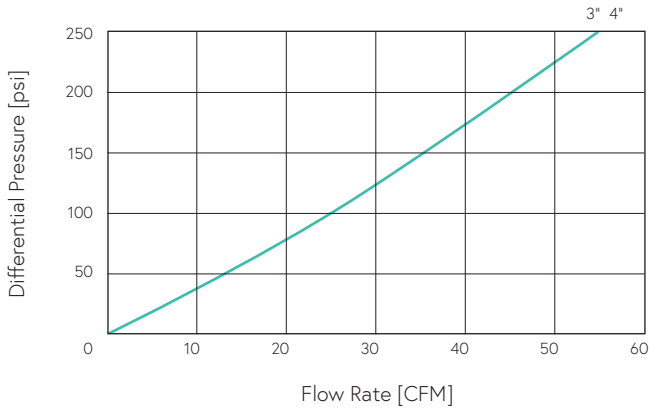

Automatic Air Release Flow Rate

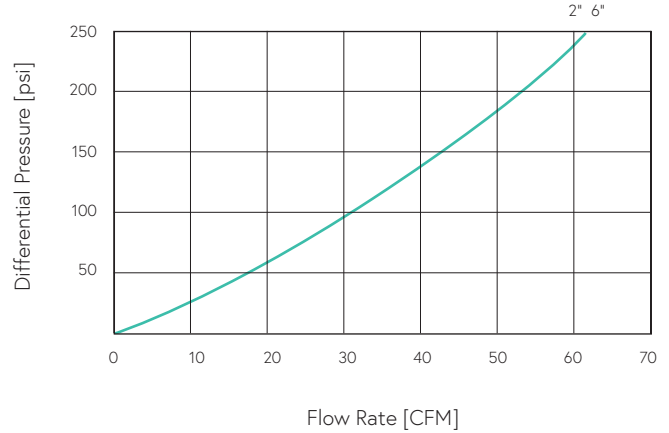

Elbow Outlet Models

Air & Vacuum Flow Rate

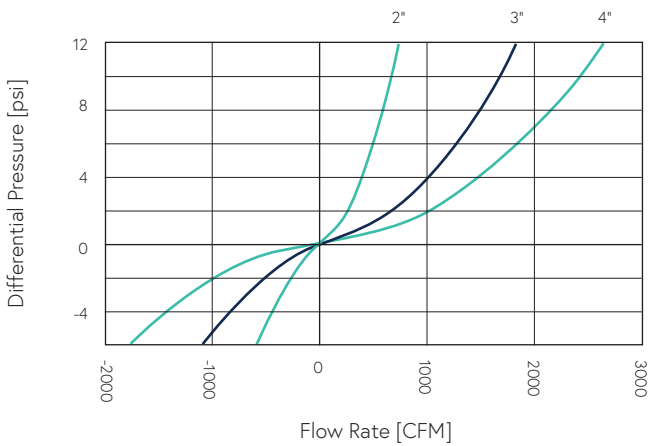

Air & Vacuum Flow Rate

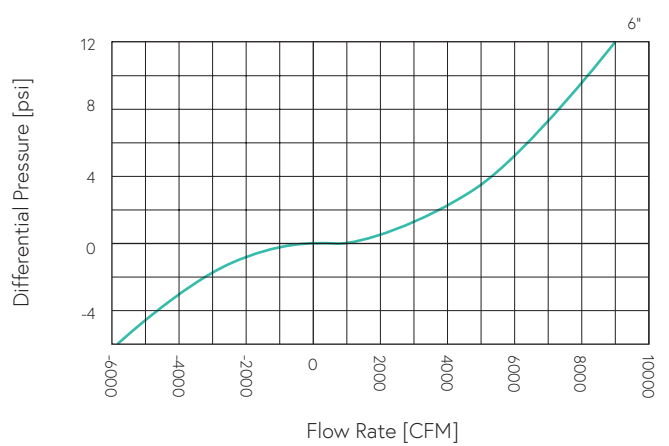

Screen Cover Outlet Models

Air & Vacuum Flow Rate

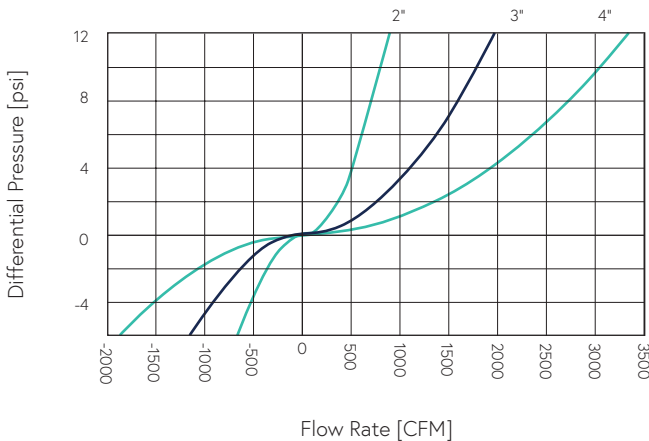

Air & Vacuum Flow Rate

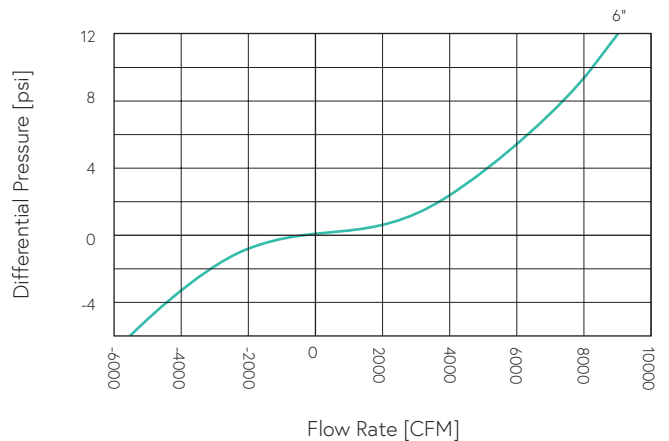

Non-slam Add-on Component Data Table for Variable Orifices

Size	Discharge orifice (Inch)	Total NS area (Sq.In)	NS orifice (Inch)	Switching point (psi)	CFM (5.8 psi)
2" (50mm)	2"	0.12	0.39	0.01	38.3
3" (80mm)	3"	0.29	0.59	0.06	105.9
4" (100mm)	4"	0.62	0.89	0.07	138.3
6" (150mm)	6"	1.37	1.34	0.44	426.7

D-46 NS - Elbow Outlet Models

Air & Vacuum Flow Rate

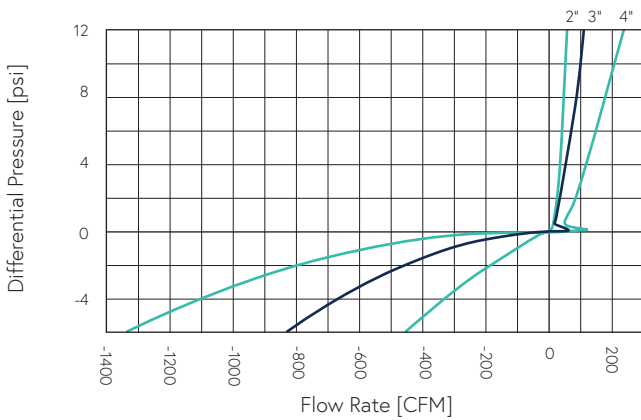

Air Discharge Switching Region

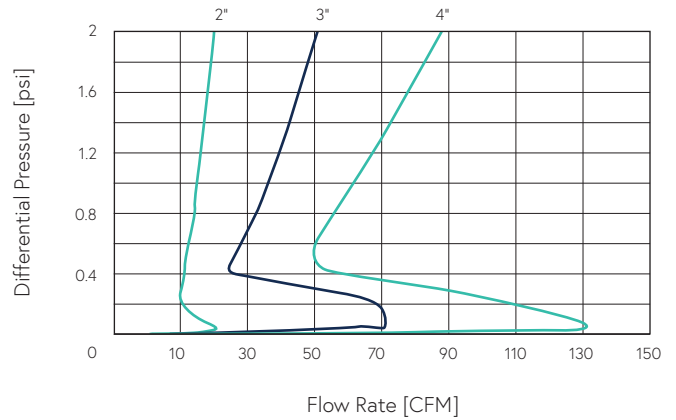

Air & Vacuum Flow Rate

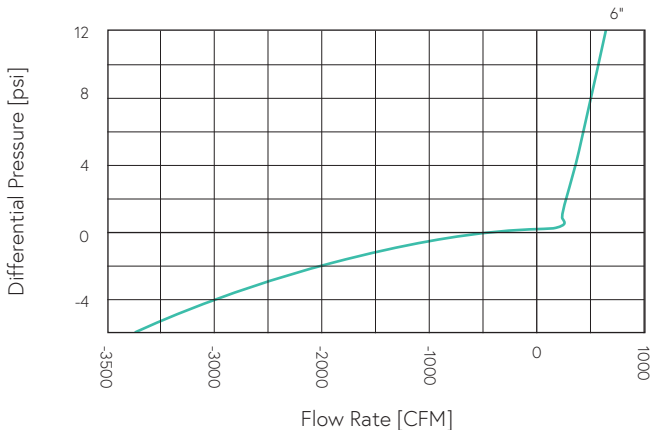

Air Discharge Switching Region

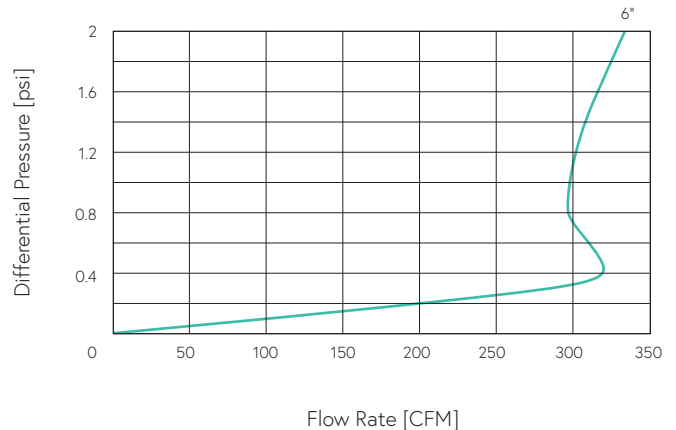

D-46 NS - Screen Cover Outlet Models

Air & Vacuum Flow Rate

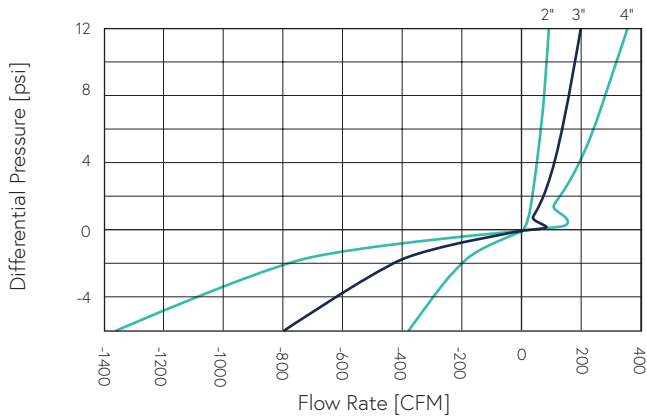

Air Discharge Switching Region

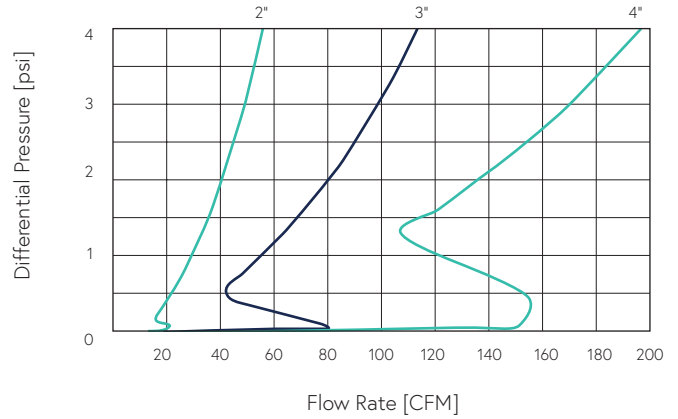

Air & Vacuum Flow Rate

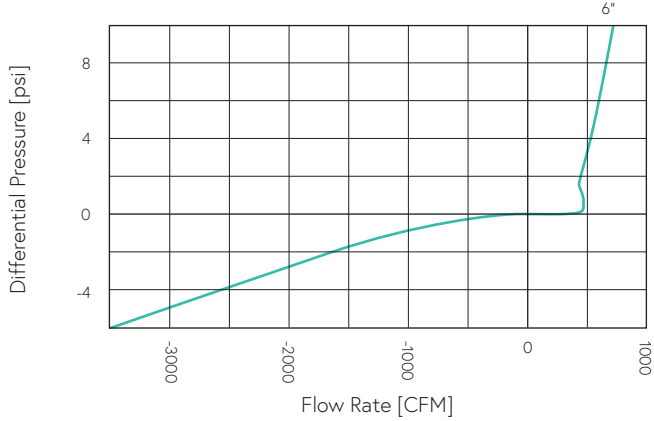

Air Discharge Switching Region

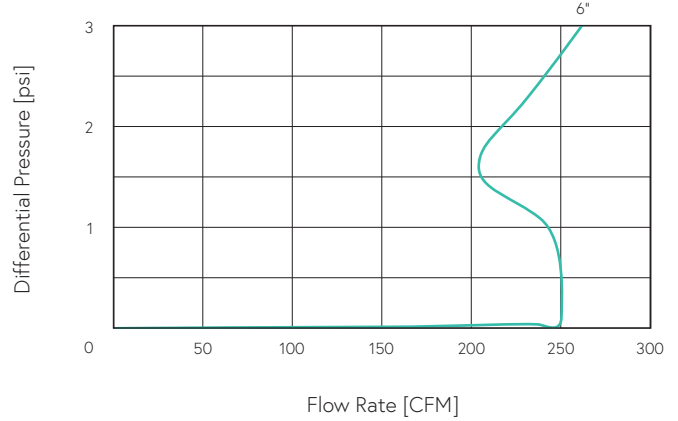

Flow Charts ST ST Models

Air & Vacuum Flow Rate

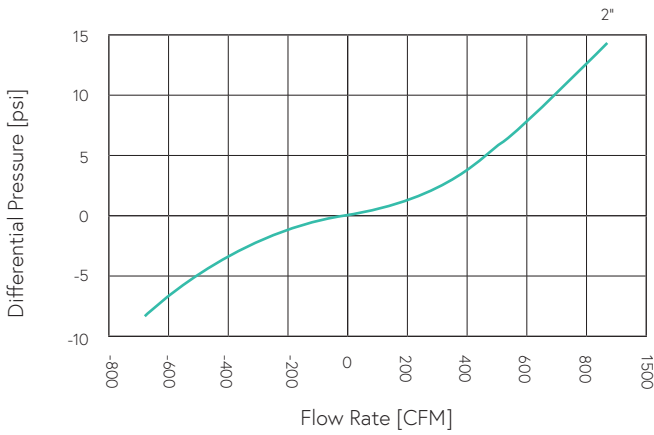

Automatic Air Release Flow Rate

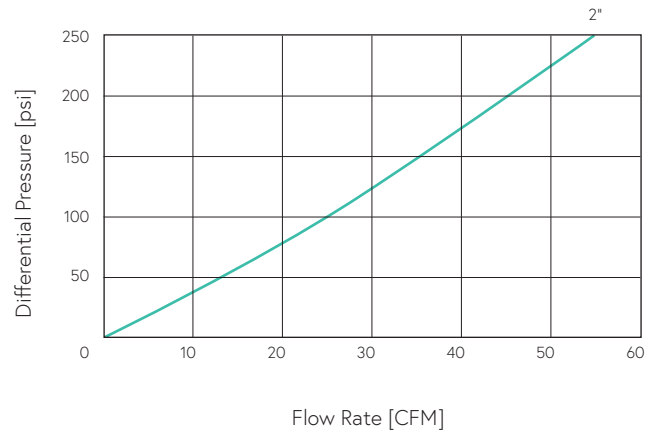

Air & Vacuum Flow Rate

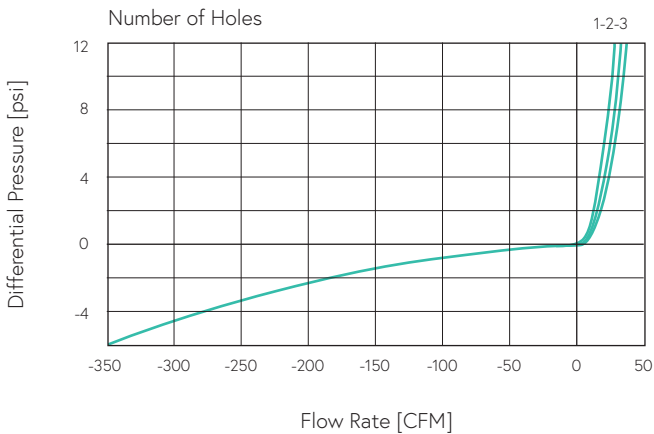

Air Flow Rate

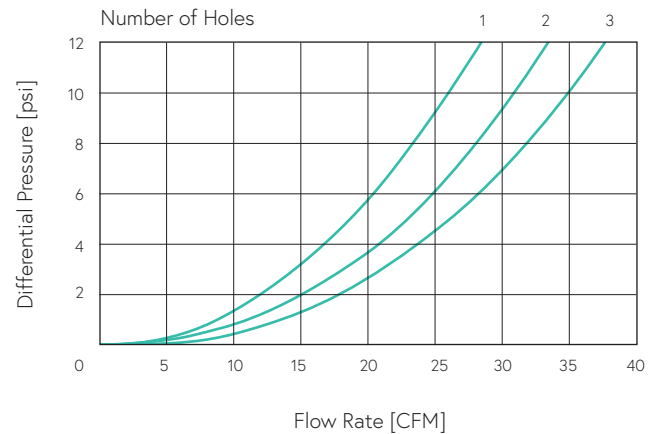

Non-slam Add-on Component Data Table for Variable Orifices

Size	Number of orifices	Discharge orifice (Inch)	Total NS area (Sq.In)	NS orifice (Inch)	Switching point (psi)	CFM (5.8 psi)
2" (50mm)	1 orifice	2"	0.024	0.18	Spring loaded normally closed	14
	2 orifices	2"	0.049	0.25		19
	3 orifices	2"	0.074	0.31		24

Parts List and Specification | 2"

Part	Material
1. Discharge Assembly	
1a. Discharge Elbow or Screen Cover	Polypropylene
1b. Seal	NBR
2. Body Assembly	
2a. Non-slam Disc (optional)	Reinforced Nylon
2b. Body	Ductile Iron
2c. Plugged Drain Outlet	Polypropylene
2d. Pressure Release Plug 1/2"	Reinforced Nylon
3. Air Release / Air & Vacuum Assembly	
3a. Air & Vacuum Seal	EPDM
3b. Air Release Cover	Acetal
3c. Rolling Seal	EPDM
3d. Float	Polypropylene
4. Seat Assembly	
4a. Float Seat	Acetal
4b. Snap Ring	Reinforced Nylon

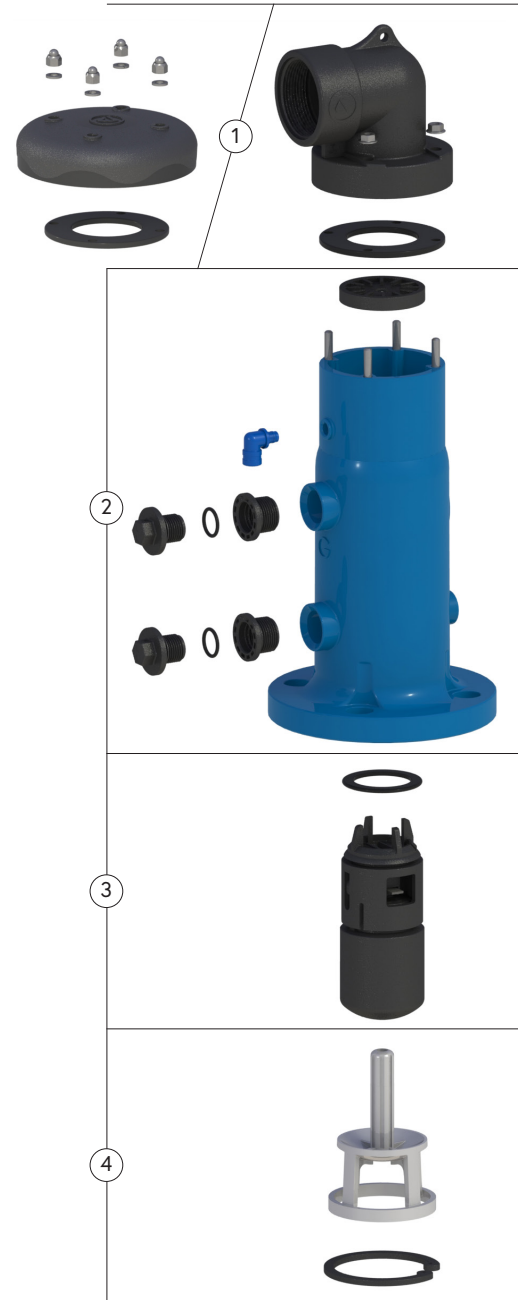

Parts List and Specification | 3" - 4"

Part	Material
1. Discharge Assembly	
1a. Discharge Elbow or Screen Cover	Polypropylene
1b. Seal	NBR
2. Body Assembly	
2a. Non-slam Disc (optional)	Reinforced Nylon
2b. Body	Ductile Iron
2c. Plugged Drain Outlet	Polypropylene
2d. Pressure Release Plug 1/2"	Reinforced Nylon
3. Air Release Assembly	
3a. Cover	Acetal
3b. O-ring	EPDM
3c. Rolling Seal	EPDM
3d. Air Release Float	Polypropylene
4. Air & Vacuum Assembly	
4a. Air & Vacuum Seal	EPDM
4b. Air & Vacuum Float	Polypropylene
5. Seat Assembly	
5a. Float Seat	Acetal
5b. Snap Ring	Reinforced Nylon

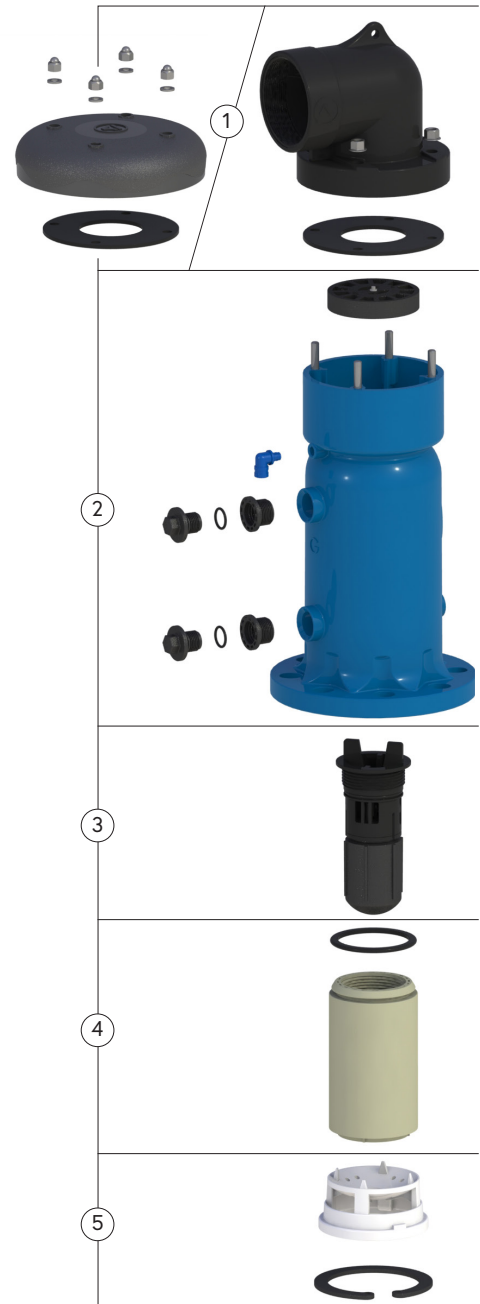

Parts List and Specification | 6"

Part	Material
1. Discharge Assembly	
1a. Discharge Elbow or Screen Cover	Polypropylene
1b. Lifting Ring	Stainless Steel 316
1c. Seal	NBR
1d. Optional for Elbow Model Flange + Locking Ring + O-ring	Polypropylene / Steel + Acetal + EPDM
2. Body Assembly	
2a. Non-slam Disc (optional)	Reinforced Nylon
2b. Body	Ductile Iron
2c. Plugged Drain Outlet	Polypropylene
2d. Pressure Release Plug 1/2"	Reinforced Nylon
3. Air Release Assembly	
3a. Cover	Reinforced Nylon
3b. O-ring	EPDM
3c. Rolling Seal	NBR
3d. Air Release Float	Foamed Polypropylene
4. Air & Vacuum Assembly	
4a. Air & Vacuum Seal	EPDM
4b. Air & Vacuum Float	Reinforced Polypropylene
5. Seat Assembly	
5a. Float Seat	Acetal
5b. Snap Ring	Acetal

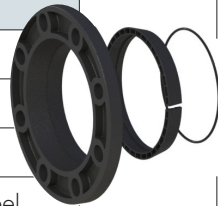

Parts List and Specifications | 2"

No.	Part	Material
1	Cover Assembly	
1a	Cover	Stainless Steel 316
1b	Elbow (optional)	Stainless Steel 316 / Polypropylene
1c	Non-slam (optional)	Reinforced Nylon
2	Air Release / Air & Vacuum Assembly	
2a	Air & Vacuum Seal	EPDM
2b	Air Release Cover	Reinforced Nylon
2c	Rolling Seal	EPDM
2d	Float	Polypropylene
2e	O-ring	NBR
3	Body Assembly	
3a	Body	Stainless Steel 316
3b	1/2" Plug	Stainless Steel 316
4	Flange Assembly (optional)	
4a	O-ring	NBR
4b	Flange	Stainless Steel 316

